

UW Series Solenoid Valve



● UW-50



● UW-25



● UW-10

■ Graphic Sign

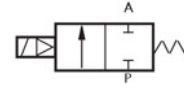

● Ordering Code

UW	—	10		AC220V
UW Series		Pipe Size:		Standard Voltage:
		10 : ZG3/8		AC24V
		15 : ZG1/2		AC110V
		20 : ZG3/4		AC220V
		25 : ZG1		DC12V
		35 : ZG1 1/4		DC24V
		40 : ZG1 1/2		
		50 : ZG2		

■ Specific Property:

This guiding type valve adopts the diaphragm seal structure, with zero differential pressure starting function, large flow, simple structure, easy maintenance, good waterproof performance and multiple wiring directions.

■ Technical Parameter

Item \ Specification	UW-10	UW-15	UW-20	UW-25	UW-35	UW-40	UW-50		
Material of Body	Foundry								
Operating Method	Film Pilot								
Pipe Size	ZG3/8	ZG1/2	ZG3/4	ZG1	ZG1¼	ZG1½	ZG2		
Nominal Diameter (mm)	16	20	20	25	37	37	50		
Applicable Fluid	Air, Water, Oil (below 50CST)								
Pressure Range	0 ~ 0.8MPa								
Applicable Temperature	-5 ~ 99°C								
Specified Voltage	AC12V	AC24V	AC36V	AC110V	AC220V	AC380V	DC12V	DC24V	DC110V
UW10-25 Power	11W	11W	10W	12 W	12W	12W	20 W	20 W	20 W
UW35-50 Power	22W	22W	22W	20 W	20W	20W	48 W	44 W	45 W
Operating Voltage Range	± 10%								
Min. Activating Time	0.05S								
Install Method	Horizontal Fixing								

■ Figure Dimension

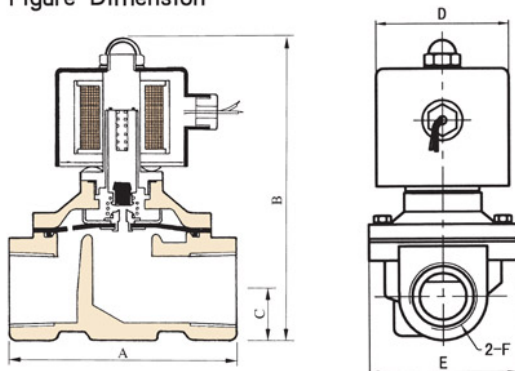

Dimension	A	B	C	D	E	F
UW-10	69	117	16	φ 50	57	ZG3/8
UW-15	69	117	16	φ 50	57	ZG1/2
UW-20	74	124	17	φ 50	57	ZG3/4
UW-25	99	135	23	φ 50	73	ZG1
UW-35	123	172	30	φ 70	95	ZG1¼
UW-40	123	172	30	φ 70	95	ZG1½
UW-50	168	209	37	φ 70	123	ZG2